



## HA400 HA900 HA401 HA901



### General Description

The HA series are digital PID controllers with a high speed sampling time of 25 ms (0.025 sec) with high-resolution thermocouple, RTD or current voltage input, supplied with parameters settable in 1/100 sec.

A difference of HA400/900 and HA401/901 is autotuning. If the process is less than 30 seconds to setpoint, the HA400/900 is best suited of which factory default values are suited for fast process.

Applications in RTP (Rapid Thermal Process), RTA (Rapid Thermal Anneal) and temperature control of semiconductor manufacturing can be controlled by the HA series. The high speed sampling function also makes it suitable for other applications requiring fast control such as pressure or flow rate.

### Features

- ☆ Ultra High Speed Sampling 0.025 sec
- ☆ Two Channels in One Controller
- ☆ Ramp / Soak Program Control
- ☆ Cascade Control
- ☆ Power Feed Forward Function
- ☆ Communications

#### Two Channels in One Controller

Dual loop control can be performed with a single controller. All loops operate at 0.025ms sampling time.

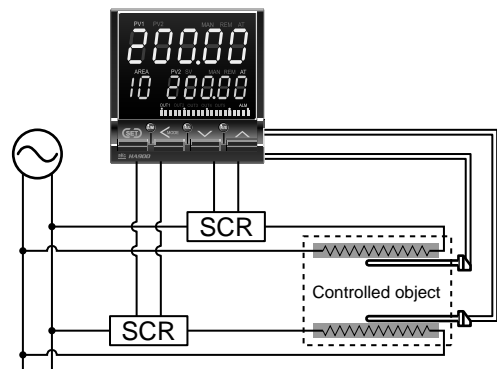

#### Ultra High Speed Sampling 0.025 sec

The HA series digital controller supplies feedback control 40 times in one second. It makes the HA series suitable for any application requiring fast control response and high accuracy. The PID parameters can be set in 1/100 unit which supports extremely fast and accurate control by the HA series.

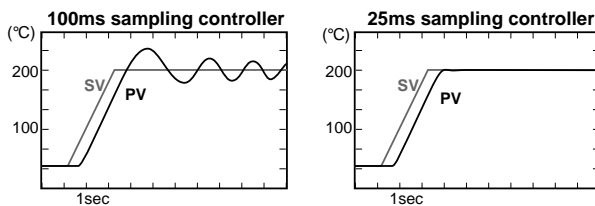

#### Cascade Control in One Controller

Cascade control can be performed with a single controller. Input type can be specified independently for each channel.

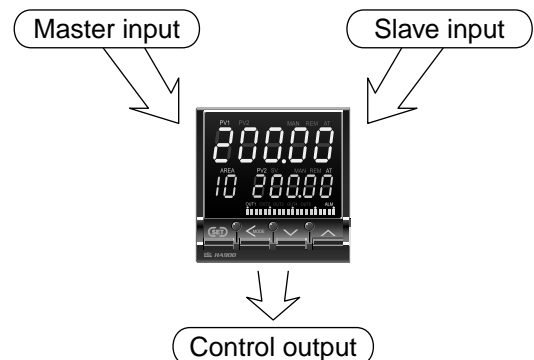

#### Direct Function keys

Direct function keys are marked for Auto/Manual, Remote/Local, and Run/Stop switching to eliminate error when entering changing patterns.

Use and Unused of each function key is also possible.

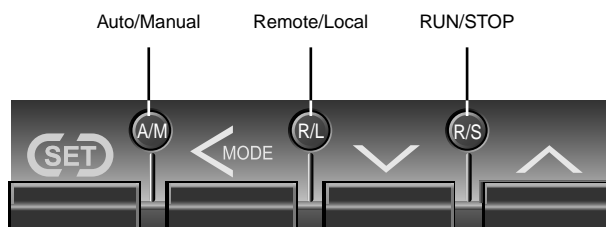

## Features

### Ramp / Soak Program Control

HA400/900 high speed temperature controller has Multi-memory Area function which stores up to 16 sets of control parameters.

Parameters stored in each memory area are the control set value, event set value, PID values, control response, ramp-to-setpoint UP and DOWN, soak time, and link area number.

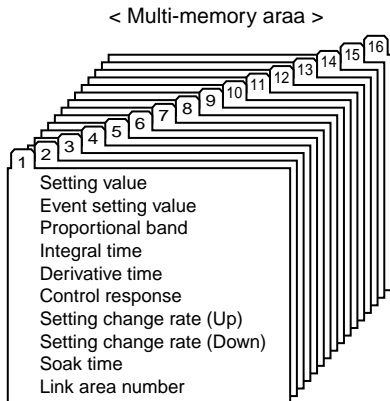

Up to 32-segment ramp/soak control is available by using the memory area function (ramp-to-set point UP and DOWN, soak time, link area number).

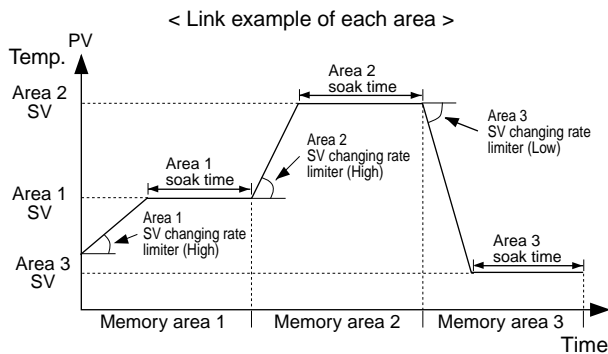

### PDA Infrared Port Communication

HA400/900 can be set and monitored with infrared port communication of PDA (Windows Pocket PC 2002).

An HA series use can download "RKC IR for HA Series" communication software from RKC's website at [www.rkcinst.com](http://www.rkcinst.com).



### Communications

(Optional)

HA400/900 incorporates a maximum of two communication ports. The communication method can be selected from serial communication (RS-485, RS-422A, RS-232C), Open network (DeviceNet, Profibus), and MAPMAN function (RKC's unique program-free connection system to PLCs).

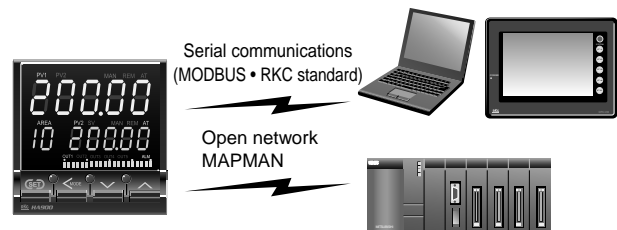

### Numerous Inputs and Outputs

A maximum of two measuring inputs (one input can be used as a remote setpoint signal) and seven event inputs can be specified. A maximum of five outputs can be specified, and various output functions (control output, analog retransmission, event up to 4) can be allocated in output logic operation.

• Available inputs and outputs depend on the specifications.

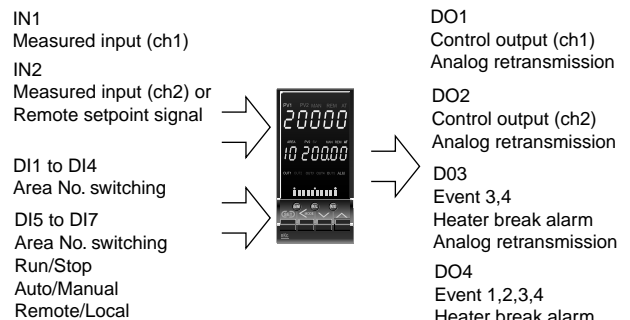

Event types :

- Deviation high, Deviation low
- Deviation high/low, Band
- Process high, Process low
- Set value high, Set value low
- LBA (Assignable to event outputs 3 and 4.)

### Suitable for Various Process Control

Using industry standard DC inputs (current and voltage), the HA400/900 can be used in process control applications including pressure, flow rate and levels.

## Specifications

### Input

#### Number of inputs

- 2 points (IN1 to IN2)
  - Isolated between each channel
  - 2nd input (IN2) can be used as a remote input
  - Cascade connection available

#### Input

- Universal input
  - a) Low voltage input group
    - Thermocouple : K, J, R, S, B, E, T, N (JIS/IEC)  
PLII (NBS), W5Re/W26Re (ASTM)
      - Influence of external resistance : Approx. 0.25 $\mu$ V/ $\Omega$
      - Input break action : Up-scale / Down-scale (Selectable)
    - RTD : Pt100 (JIS/IEC), JPt100 (JIS)
      - Influence of input lead resistance : Approx. 0.01[ $^{\circ}$ C/ $\Omega$ ] of reading
      - Maximum 10 $\Omega$  per wire
      - Input break action : Up-scale
    - Low voltage : 0 to 1V DC, 0 to 100mV DC, 0 to 10mV DC
      - Input break action : Up-scale / Down-scale (Selectable)
    - Current : 4 to 20mA DC, 0 to 20mA DC
      - Input break action : Uncertain (indicates a value around 0mA)
  - b) High voltage input group
    - High voltage : 0 to 5V DC, 1 to 5V DC, 0 to 10V DC
      - Input break action : Uncertain (indicates a value around 0V)

#### Sampling Time

0.025 sec

#### Input Digital Filter

0.01 to 10.00 sec (OFF when 0 is set.)

#### PV Bias

-span to +span

#### PV Ratio

0.500 to 1.500

#### Square Root Extraction

Equation :  $PV = \sqrt{\text{Input value} \times \text{PV ratio} + \text{PV bias}}$   
Low level cut OFF : 0.00 to 25.00% of span

### Performance

#### Measuring Accuracy

- a) Thermocouple
  - Type : K, J, T, E, PLII
    - Less than -100 $^{\circ}$ C (-148 $^{\circ}$ F) :  $\pm 1.0^{\circ}$ C ( $\pm 1.8^{\circ}$ F)
    - 100 to 500 $^{\circ}$ C (-148 to 932 $^{\circ}$ F) :  $\pm 0.5^{\circ}$ C ( $\pm 0.9^{\circ}$ F)
    - More than 500 $^{\circ}$ C (932 $^{\circ}$ F) :  $\pm 0.1\%$  of Reading + 1 digit
  - Type : N, S, R, W5Re/W26Re
    - Less than -100 $^{\circ}$ C (-148 $^{\circ}$ F) :  $\pm 2.0^{\circ}$ C ( $\pm 3.6^{\circ}$ F)
    - 100 to 1000 $^{\circ}$ C (-148 to 1832 $^{\circ}$ F) :  $\pm 1.0^{\circ}$ C ( $\pm 1.8^{\circ}$ F)
    - More than 1000 $^{\circ}$ C (1832 $^{\circ}$ F) :  $\pm 0.1\%$  of Reading + 1 digit
  - Type : B
    - Less than 400 $^{\circ}$ C (752 $^{\circ}$ F) :  $\pm 70.0^{\circ}$ C ( $\pm 126^{\circ}$ F)
    - 400 to 1000 $^{\circ}$ C (752 to 1832 $^{\circ}$ F) : 1.0 $^{\circ}$ C (1.8 $^{\circ}$ F)
    - More than 1000 $^{\circ}$ C (1832 $^{\circ}$ F) :  $\pm 0.1\%$  of Reading + 1 digit
- Cold junction temperature compensation error
  - $\pm 1.0^{\circ}$ C (1.8 $^{\circ}$ F) [at 23 $^{\circ}$ C $\pm 2^{\circ}$ C (73.4 $^{\circ}$ F $\pm 3.6^{\circ}$ F)]
  - Within  $\pm 1.5^{\circ}$ C ( $\pm 2.7^{\circ}$ F) [Between 0 and 50 $^{\circ}$ C (14 to 122 $^{\circ}$ F)]
- b) RTD
  - Less than 200 $^{\circ}$ C (392 $^{\circ}$ F) :  $\pm 0.2^{\circ}$ C ( $\pm 0.4^{\circ}$ F)
  - More than 200 $^{\circ}$ C (392 $^{\circ}$ F) :  $\pm 0.1\%$  of Reading + 1 digit
- c) DC voltage and DC current
  - $\pm 0.1\%$  of span

#### Insulation Resistance

More than 20M $\Omega$  (500V DC) between measured terminals and ground  
More than 20M $\Omega$  (500V DC) between power terminals and ground

#### Dielectric Strength

1000V AC for one minute between measured terminals and ground  
1500V AC for one minute between power terminals and ground

### Control

#### Control Method

- a) Brilliant PID control with enhanced autotuning.
    - Available for reverse and direct action.
  - b) Position proportioning control.
- a) or b) is selectable.

#### Major Setting Range

Set value : Same as input range.  
Proportional band : 0 to input span (Temperature input)  
0.0 to 1000.0% of span (Voltage, Current input)  
Integral time : 0.00 to 360.00sec. or 0.0 to 3600.0sec.  
(selectable)  
Derivative time : 0.00 to 360.00sec. or 0.0 to 3600.0sec.  
(selectable)  
Control response : Slow, Medium, Fast  
Output limiter : -5.0 to +105.0% (High/Low individual setting)  
Output change rate limiter : 0.0 to 100.0%/sec. (Up/Down individual setting)  
Proportional cycle time : 0.1 to 100.0 sec.  
Memory area : 16 sets

#### Motor Valve Control (position proportioning control type only)

Input resistance (feedback resistance) : 135 $\Omega$  as standard  
POS sampling cycle : 0.075 sec.  
Neutral zone : 0.1 to 10.0% (output), resolution 0.1%  
Output : Relay output  
Motor rotating speed : Suitable for ??? to ??? sec. (full open to full close)  
• When motor valve control is used, neither heater break alarm nor power feed forward function is available.

### Output

#### Main Output

Number of output : Up to 3 points (OUT1 to OUT3)  
Output function : OUT1, 2 : Control output  
OUT3 : Event output or analog retransmission output (Optional)  
Output type : Relay output :  
Form A contact, 250V AC 3A (resistive load)  
Voltage pulse output : 0/12V DC  
(Load resistance : More than 600 $\Omega$ )  
Current output : 4 to 20mA DC, 0 to 20mA DC  
(Load resistance : Less than 600 $\Omega$ )  
Continuous voltage output :  
0 to 5V DC, 1 to 5V DC, 0 to 10V DC  
(Load resistance : More than 1k $\Omega$ )  
SSR (Triac) output (Rated current : 0.4A)

#### Sub Output (Optional)

Number of output : Up to 2 points (OUT4, OUT5)  
Output function : Event output (Optional)  
Output type : Relay output :  
Form A contact, 250V AC 1A (resistive load)

### Event (Alarm) Output (Optional)

#### Number of Event Outputs

Up to 4 points (Event 1 to 4)

#### Alarms

Type : Deviation High, Low, High/Low, Band,  
Process High, Low  
Set value High, Low  
Differential gap : 0 to input span

#### Heater Break Alarm (For single phase)

CT type : CTL-6-P-N(30A), CTL-12-S56-10L-N(100A)  
Display range : 0.0 to 100.0A  
Accuracy :  $\pm 5\%$  of input value or  $\pm 2A$  (whichever is larger)

#### Control Loop Break Alarm (LBA)

LBA time setting : 0.1 to 7200 sec. (OFF by setting zero)  
LBA deadband : 0 to input span

#### Output

Assignable to main output (OUT3) or sub output (OUT4 to 5).

#### Other Functions

HOLD action (Valid for deviation/band/PV alarms only)  
Selection of event action for input abnormality.



## Specifications

### Non-isolated Remote Setpoint Input (Optional)

◆ Only available in a 1 channel control type.

#### Input

- a) 0 to 1V DC, 0 to 100mV DC, 0 to 10mV DC
- b) 0 to 5V DC, 1 to 5V DC, 0 to 10V DC
- c) 4 to 20mA DC, 0 to 20mA DC

#### Accuracy

0.1% of span

### Event Input (Optional)

#### Number of Inputs

Up to 7 points

#### Input Rating

Non-voltage contact input

#### Functions

- a) Memory area selection
- b) Run/Stop switching
- c) Remote/Local switching
- d) Auto/Manual switching

• Event input logic selection functional allocation table

	DI1	DI2	DI3	DI4	DI5	DI6	DI7
1	Memory area selection (1 to 16)			Area set	Run/Stop	Auto/Manual	
2	Memory area selection (1 to 16)			Area set	Run/Stop	Remote/Local	
3	Memory area selection (1 to 16)			Area set	Remote/Local	Auto/Manual	
4	Memory area selection (1 to 8)		Area set	Run/Stop	Remote/Local	Auto/Manual	
5	Memory area selection (1 to 8)		Area set	Remote/Local			
6	Memory area selection (1 to 8)		Area set	Auto/Manual			

### Analog Retransmission Output (Optional)

#### Number of Outputs

Up to 3 points

- Functions are assignable to OUT1 to OUT3.

#### Output types

- a) Measured value (PV)
- b) Deviation (DV)
- c) Set value (SV)
- d) Manipulated output value (MV)

### Communications (Optional)

Number of communications : 2 points

Communication method : COM1: RS-485, RS-232C  
COM2: RS-232C, RS-485, RS-422A  
DeviceNet, PROFIBUS

Communication speed : 2400, 9600, 19200, 38400 BPS

Protocol : ANSI X3.28(1976) 2.5 A4  
MODBUS

#### Bit format

Start bit : 1  
Data bit : 7 or 8 •For MODBUS 8 bit only  
Parity bit : Without, Odd or Even  
Stop bit : 1 or 2

Communication code : ASCII(JIS) 7-bit code

Maximum connection : RS-485, RS-422A : 31  
( Address can be set from 0 to 99.)  
RS-232C : 1

### Infrared Port Communication

Infrared Port : IrDA standard

Software Name : RKC IR for HA Series

Support OS : Windows Pocket PC 2002

- This software is offered from RKC's website at [www.rkcinst.com](http://www.rkcinst.com).

### Waterproof/Dustproof (Optional)

Waterproof/dustproof protection : IP65

- Waterproof/dustproof protection only effective from the front in panel mounted installations.

### General Specifications

#### Supply Voltage

- a) 90 to 264V AC (Including supply voltage variation)  
[Rating : 100 to 240V AC] (50/60Hz common)
- b) 21.6 to 26.4V AC (Including supply voltage variation)  
[Rating : 24V AC] (50/60Hz common)
- c) 21.6 to 26.4V DC (Ripple rate 10% p-p or less) [Rating:24VDC]

#### Power Consumption

- HA400 : Less than 22.5VA for AC type (at 240V AC)  
Less than 15.0VA for 24V AC type  
Less than 430mA for 24V DC type
- HA900 : Less than 24.0VA for AC type (at 240V AC)  
Less than 16.0VA for 24V AC type  
Less than 470mA for 24V DC type

#### Power Failure Effect

Not affected by power failure shorter than 20msec, otherwise reset to the initial state. (HOT or COLD start is selectable.)

#### Self-Diagnostic Function

CPU power check, Adjustment data check, EEPROM check, RAM check, etc..

#### Operating Environments : -10 to 50°C [14 to 122°F]

5 to 95% RH.  
29g/m<sup>3</sup> dry air at 101.3kPa AH.

#### Memory Backup : Backed up by non-volatile memory.

Number of writing : Approx. 100,000 times

#### Net Weight

- HA400 : Approx. 360g
- HA900 : Approx. 460g

#### External Dimensions (W x H x D)

- HA400 : 48 x 96 x 100mm
- HA900 : 96 x 96 x 100mm

### Compliance with Standards

- CE Mark
- UL Recognized
- CSA Certified
- C-Tick Mark



## Model and Suffix Code

### 1 channel control type

Specifications	Model and Suffix Code									
Model	HA400 (48 x 96mm 1/8 DIN size) HA900 (96 x 96mm 1/4 DIN size) HA401 (48 x 96mm 1/8 DIN size) HA901 (96 x 96mm 1/4 DIN size) <span style="float: right;">-□ □-□ □-□*□ □-□ □ □ □-□/□/□</span>									
Input (IN1 : No 1 input)	See Input and Range code table									
Non isolated type remote set value	Not supplied	0								
	See Remote input code table	□								
Output 1 (Main output)	1 3 Relay contact output Voltage pulse output : 0/12V DC DC voltage : 0 to 5V DC voltage : 0 to 10V DC voltage : 1 to 5V DC current : 0 to 20mA DC current : 4 to 20mA SSR (Triac) output	M	V							
		4								
		5								
		6								
		7								
		8								
		T								
Output 2 (Main output) * Not isolated from OUT1.	1 3 No output from OUT2 Relay contact output Voltage pulse output : 0/12V DC DC voltage : 0 to 5V DC voltage : 0 to 10V DC voltage : 1 to 5V DC current : 0 to 20mA DC current : 4 to 20mA SSR (Triac) output	N	M							
		V								
		4								
		5								
		6								
		7								
		8								
		T								
Power supply	24V AC/DC 100 to 240V AC					3				
						4				
Output 3 (Main output)	2 3 No output from OUT3 Relay contact output Voltage pulse output : 0/12V DC DC voltage : 0 to 5V DC voltage : 0 to 10V DC voltage : 1 to 5V DC current : 0 to 20mA DC current : 4 to 20mA SSR (Triac) output	N	M							
		V								
		4								
		5								
		6								
		7								
		8								
		T								
Output 4, 5 (OUT4, 5 : Sub output)	No outputs from OUT4 and OUT5 OUT4 : Relay contact output, No output from OUT5 OUT4 and OUT5 : Relay contact output					N				
						1				
						2				
Event input 1 to 5	Not supplied Event input : 5 points (DI 1 to DI5)						N			
							1			
CT input, Power feed forward (PFF) input, Feedback resistance	Not supplied CT input 1 point (CTL-6-P-N) CT input 1 point (CTL-12-S56-10L-N) CT input 2 points (CTL-6-P-N) CT input 2 points (CTL-12-S56-10L-N) PFF input (Within transformer 100 to 120V AC type) PFF input (Within transformer 200 to 240V AC type) CT input 1 point (CTL-6-P-N) + PFF input (Within transformer 100 to 120V AC type) CT input 1 point (CTL-6-P-N) + PFF input (Within transformer 200 to 240V AC type) CT input 1 point (CTL-12-S56-10L-N) + PFF input (Within transformer 100 to 120V AC type) CT input 1 point (CTL-12-S56-10L-N) + PFF input (Within transformer 200 to 240V AC type) Feedback resistance input						N			
								P		
								S		
								T		
								U		
								1		
								2		
								3		
								4		
								5		
								6		
								F		
Communication 1 or Event input 6 to 7	Not supplied RS-232C (ANSI/RKC standard) RS-485 (ANSI/RKC standard) RS-485 (MODBUS) RS-232C (MODBUS) Event input : DI6 and DI7							N		
								1		
								5		
								6		
								8		
								D		
Communication 2	Not supplied RS-232C (ANSI/RKC standard) RS-422A (ANSI/RKC standard) RS-485 (ANSI/RKC standard) RS-485 (MODBUS) RS-422A (MODBUS) RS-232C (MODBUS) DeviceNet PROFIBUS							N		
								1		
								4		
								5		
								6		
								7		
								8		
								A		
								B		
Waterproof/Dustproof	Not supplied Waterproof/Dustproof protection								N	
									1	
Body color	White Black									N
										A
Instrument version	Version symbol									Y

1 Only OUT1 and OUT2 can be used for control outputs.  
 2 Event (alarm) outputs, heater break alarm outputs are assignable to OUT3 - OUT5.  
 3 Analog output (PV, SV, etc) are assignable to OUT1 - OUT3.

#### Caution

- If two isolated analog outputs are required, use OUT1 (or OUT2) and OUT3. OUT1 and OUT2 are not isolated.
- To use as a position proportioning controller, two or more outputs must be supplied.
- If heater break alarm is assigned to event function, current transformer (sold separately) is required.

# High-Speed Digital Controller - 1 or 2 loops HA Series

## Model and Suffix Code

### 2 channel control type

Specifications	Model and Suffix Code									
Model	HA400 (48 x 96mm 1/8 DIN size)      - □ □ - □ □ - □ * □ □ □ □ □ □ □ - □ / □ / □ HA900 (96 x 96mm 1/4 DIN size) HA401 (48 x 96mm 1/8 DIN size) HA901 (96 x 96mm 1/4 DIN size)									
Input 1 (IN1 : No 1 input)	See Input and Range code table									
Input 2 (IN2 : No 2 input)	See Input and Range code table									
Output 1 (Main output)	1 3	Relay contact output Voltage pulse output : 0/12V DC DC voltage : 0 to 5V DC voltage : 0 to 10V DC voltage : 1 to 5V DC current : 0 to 20mA DC current : 4 to 20mA SSR (Triac) output	M V 4 5 6 7 8 T							
Output 2 (Main output) * Not isolated from OUT1.	1 3	No output from OUT2 Relay contact output Voltage pulse output : 0/12V DC DC voltage : 0 to 5V DC voltage : 0 to 10V DC voltage : 1 to 5V DC current : 0 to 20mA DC current : 4 to 20mA SSR (Triac) output	N M V 4 5 6 7 8 T							
Power supply		24V AC/DC 100 to 240V AC		3 4						
Output 3 (Main output)	2 3	No output from OUT3 Relay contact output Voltage pulse output : 0/12V DC DC voltage : 0 to 5V DC voltage : 0 to 10V DC voltage : 1 to 5V DC current : 0 to 20mA DC current : 4 to 20mA SSR (Triac) output	N M V 4 5 6 7 8 T							
Output 4, 5 (OUT4, 5 : Sub output)	2	No outputs from OUT4 and OUT5 OUT4 : Relay contact output, No output from OUT5 OUT4 and OUT5 : Relay contact output		N 1 2						
Event input 1 to 5		Not supplied Event input : 5 points (DI 1 to DI5)		N 1						
CT input, Power feed forward (PFF) input, Feedback resistance		Not supplied CT input 1 point (CTL-6-P-N) CT input 1 point (CTL-12-S56-10L-N) CT input 2 points (CTL-6-P-N) CT input 2 points (CTL-12-S56-10L-N) PFF input (Within transformer 100 to 120V AC type) PFF input (Within transformer 200 to 240V AC type) CT input 1 point (CTL-6-P-N) + PFF input (Within transformer 100 to 120V AC type) CT input 1 point (CTL-6-P-N) + PFF input (Within transformer 200 to 240V AC type) CT input 1 point (CTL-12-S56-10L-N) + PFF input (Within transformer 100 to 120V AC type) CT input 1 point (CTL-12-S56-10L-N) + PFF input (Within transformer 200 to 240V AC type) Feedback resistance input			N P S T U 1 2 3 4 5 6 F					
Communication 1 or Event input 6 to 7		Not supplied RS-232C (ANSI/RKC standard) RS-485 (ANSI/RKC standard) RS-485 (MODBUS) RS-232C (MODBUS) Event input : DI6 and DI7			N 1 5 6 8 D					
Communication 2		Not supplied RS-232C (ANSI/RKC standard) RS-422A (ANSI/RKC standard) RS-485 (ANSI/RKC standard) RS-485 (MODBUS) RS-422A (MODBUS) RS-232C (MODBUS) DeviceNet PROFIBUS			N 1 4 5 6 7 8 A B					
Waterproof/Dustproof		Not supplied Waterproof/Dustproof protection			N 1					
Body color		White Black							N A	
Instrument version		Version symbol								Y

1 Only OUT1 and OUT2 can be used for control outputs.

2 Event (alarm) outputs, heater break alarm outputs are assignable to OUT3 - OUT5.

3 Analog output (PV, SV, etc) are assignable to OUT1 - OUT3.

#### Caution

- If two isolated analog outputs are required, use OUT1 (or OUT2) and OUT3. OUT1 and OUT2 are not isolated.
- To use as a position proportioning controller, two or more outputs must be supplied.
- If heater break alarm is assigned to event function, current transformer (sold separately) is required.

# High-Speed Digital Controller - 1 or 2 loops HA Series

## Range and Input Table

Thermocouple, RTD, Low voltage and Current group

Input	Code	Range		Resolution
K	K	-200 - 1372°C	-328 - 2501°F	1°C, 0.1°C, 1°F, 0.1°F (Selectable)
J	J	-200 - 1200°C	-328 - 2192°F	
T	T	-200 - 400°C	-328 - 752°F	
E	E	-200 - 1000°C	-328 - 1832°F	
PLII	A	0 - 1390°C	32 - 2534°F	
N	N	0 - 1300°C	32 - 2372°F	
S	S	-50 - 1768°C	-58 - 3214°F	
R	R	-50 - 1768°C	-58 - 3214°F	
W5Re/W26Re	W	0 - 2300°C	32 - 4172°F	
B	B	0 - 1800°C	32 - 3272°F	
Pt100 (3 wire)	D	-200 - 850°C	-328 - 1562°F	1°C, 0.1°C, 0.01°C 1°F, 0.1°F, 0.01°F (Selectable)
JPt100 (3 wire)		-200 - 600°C	-328 - 1112°F	
Pt100 (4 wire)	C	-200 - 850°C	-328 - 1562°F	
JPt100 (4 wire)		-200 - 600°C	-328 - 1112°F	
0 - 10mV DC	3	-19999 - 99999 (Programmable)	1, 0.1, 0.01, 0.001, 0.0001 (Programmable)	
0 - 100mV DC				
0 - 1V DC				
0 - 20mA DC				
4 - 20mA DC	8			

High voltage group

0 - 5V DC	6	-19999 - 99999 (Programmable)	1, 0.1, 0.01, 0.001, 0.0001 (Programmable)
0 - 10V DC			
1 - 5V DC			

## Remote Signal Code Table

Not isolated from the No.1 input [IN1]

Input type		Code
Low voltage group	0 - 10mV DC	G
	0 - 100mV DC	
	0 - 1V DC	
High voltage group	0 - 5V DC	V
	0 - 10V DC	
	1 - 5V DC	
Current group	0 - 20mA DC	Y
	4 - 20mA DC	

## Power Feedback Transformer (for Power Feed Forward Input)

- Supplied when power feed forward function is specified.
- When ordering transformer for replacement, please specify one of the following model codes :

Specification	Model Code
100 to 120V AC type	PFT - 01
200 to 240V AC type	PFT - 02

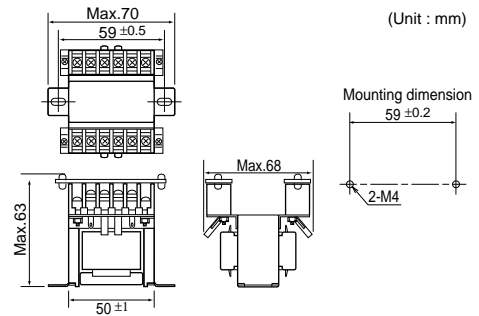

## Current Transformer (CT)

- Sold separately.

Name	Range	Model Code
Current transformer for heater break alarm	0 - 30A	CTL-6-P-N
	0 - 100A	CTL-12-S56-10L-N

### CTL-6-P-N

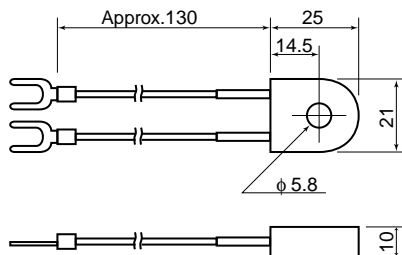

### CTL-12-S56-10L-N

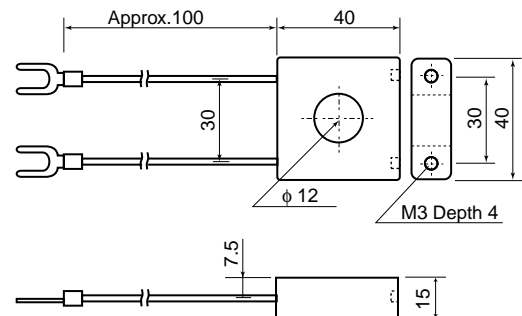

(Unit : mm)

# High-Speed Digital Controller - 1 or 2 loops HA Series

## External Dimensions and Rear Terminals

Unit : mm

### HA900, HA901

1	49	37	25	13
2	50	38	26	14
3	51	39	27	15
4	52	40	28	16
5	53	41	29	17
6	54	42	30	18
7	55	43	31	19
8	56	44	32	20
9	57	45	33	21
10	58	46	34	22
11	59	47	35	23
12	60	48	36	24

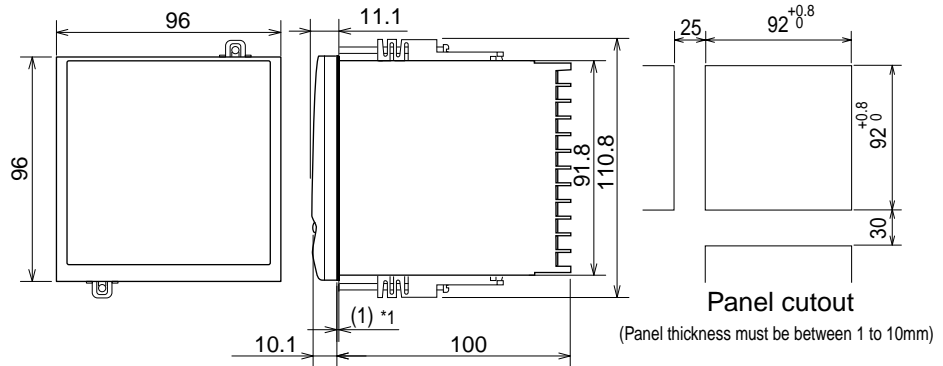

\*1 IP65 waterproof/dustproof protection is molded into case and can not be added in the field.

### HA400, HA401

1	25	13
2	26	14
3	27	15
4	28	16
5	29	17
6	30	18
7	31	19
8	32	20
9	33	21
10	34	22
11	35	23
12	36	24

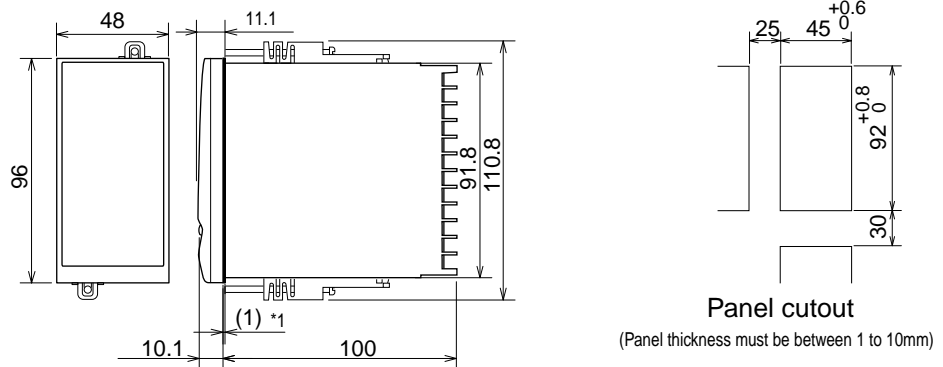

\*1 IP65 waterproof/dustproof protection is molded into case and can not be added in the field.

No	Description	No	Description	No	Description
1	100 - 240V AC 24V AC 24V DC	49 37	Not used	25	Communication * (1) RS-422A (2) RS-485 (3) RS-232C
2	Power supply	50 38		26	Communication
3	Relay contact output	51 39		27	
4	Output 5 (OUT5) *	52 40		28	
5	Relay contact output	53 41		29	Communication *
6	Output 4 (OUT4) *	54 42		30	
7	Relay contact output	55 43		31	Event input 1 to 4
8	Output 3 (OUT3) * (1) Relay contact output (2) Voltage pulse/Current/ Voltage output (3) SSR (Triac) output	56 44		32	
9	Output 2 (OUT2) * (1) Relay contact output (2) Voltage pulse/Current/ Voltage output (3) SSR (Triac) output	57 45		33	
10	Output 1 (OUT1) (1) Relay contact output (2) Voltage pulse/Current/ Voltage output (3) SSR (Triac) output	58 46		34	
11	Output 1 (OUT1) (1) Relay contact output (2) Voltage pulse/Current/ Voltage output (3) SSR (Triac) output	59 47		35	Event input 5 *
12	Output 1 (OUT1) (1) Relay contact output (2) Voltage pulse/Current/ Voltage output (3) SSR (Triac) output	60 48		36	
13	COM (A) (B)			13	(A) Communication 1 * (1) RS-485 (2) RS-232C
14	T/R (A) SD			14	(B) Event input 6 to 7 Non-voltage contact input
15	T/R (B) RD			15	
16	COM (A) OPEN (B) COM (C)			16	(A) CT1, CT2 input *
17	CT1 CT2			17	(B) Feedback resistance input
18	COM (A) OPEN (B) COM (C)			18	(C) CT1 input + Power feed forward input
19	Non isolated type remote input			19	* (A) 1 channel type No.1 Input (IN1) + Non-isolated type remote input
20	No.1 Input (IN 1)			20	
21	No.1 Input (IN 1)			21	* (B) 2 channel type No.1 Input (IN1) + No.2 Input (IN 2) (1) Thermocouple (2)-1 RTD (3 or 4 wire) (2)-2 RTD (3 wire) (3) Voltage/Current
22	No.1 Input (IN 1)			22	
23	No.1 Input (IN 1)			23	
24	No.1 Input (IN 1)			24	

\* Functions (A) to (C) and types (1) to (3) must be specified when instrument is ordered as change can not be made in the field.

\* : Option